

Instructions for Using the Assembled Schmitt Photogate Trigger with Individual Emitter and Detector (SPG1-DU-A)

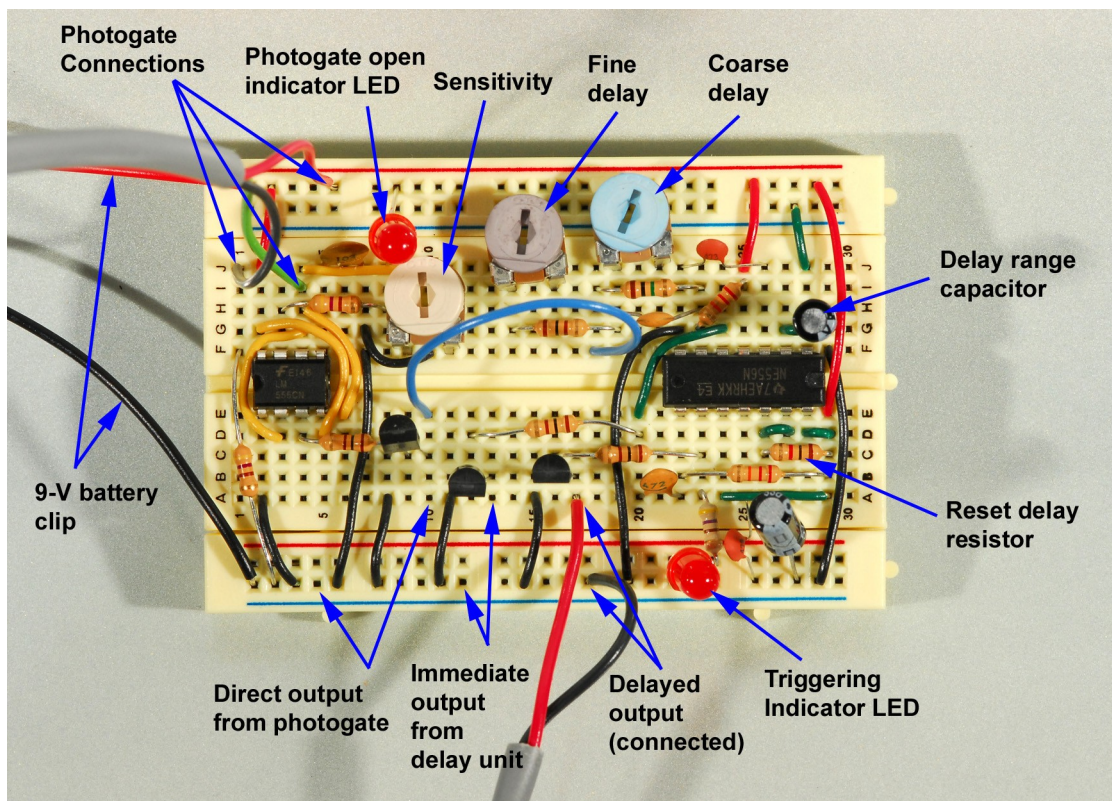

Supplied components

Circuit board with photogate and delay unit
 Photogate cable with wired emitter and detector
 3-foot, 2-conductor output cable

Small bag with these components:
 0.01- μ f capacitor (103)
 0.1- μ f capacitor (104)
 100-kohm resistor (brown-black-yellow)

Battery cable connection

The entire column of holes on the bottom along the blue line is negative (ground). Likewise, the entire column along the red line on the top is +9 V. These two columns are where the red and black cables from the battery clip are connected.

Connecting the photogate cable

The photogate cable has 3 wires: red, black, and green. The emitter (blue) and detector (clear) have already been soldered onto one end of the cable. The other end is connected to your circuit as shown to the right in case you need to reconnect the cable.

Wire	Location
Red	+
Black	1J
Green	4I

For testing and use, position the emitter and detector so that they are facing each other a few inches apart. Make sure they can't move as this will affect the sensitivity adjustment. Separations up to about 6 inches are possible, but the sensitivity must be adjusted critically for large separations. See the section below on how to adjust sensitivity.

Connecting the output cable

The output cable has 2 wires: red and black. Make the following connections, depending on which mode of output you would like to use:

Output Mode	Red Wire	Black Wire
directly from photogate (no delay)*	10A	(-)
from the immediate output of the delay unit	13A	(-)
from the delayed output	17A	(-)

Connect the other end of the output cable to the PC cord from your flash unit. See the following link for illustrated instructions on splicing the output cable to a PC cord or Flash-to-PC adapter:

http://hiviz.com/kits/instructions/flash_info.htm.

*If you're connecting the output cable directly to the photogate output (no delay), be sure to disconnect the wire from 10E to 18F first.

Connecting the output cable to a camera or wireless trigger

If you wish to trigger either a wireless transmitter or your camera shutter instead of a flash unit, see this page:

http://hiviz.com/kits/instructions/camera_wireless_info.htm.

Powering the unit

The circuit runs on a 9-V battery. Connect the wires from the battery clip to the +9 V and ground columns. Disconnect the battery when the circuit is not in use. You may also choose to use a 9-V AC/DC adapter to power the unit. Any AC/DC adapter that provides up to an ampere of direct current at 9 V should do. Here's an example: http://hiviz.com/kits/ACDC_adapter.htm.

Connecting the trigger to the delay unit

The jumper wire connecting the photogate to the delay unit runs from 10E (photogate output) to 18F (delay unit input). For testing the delay unit without the photogate, you can remove the jumper wire from 10E and touch it momentarily to ground. The triggering indicator LED should light momentarily if the delay unit is working correctly.

Photogate open indicator LED

When the photogate is aligned and unblocked, the red photogate indicator LED will be on. The LED will go off when the photogate is blocked.

The red LEDs aren't needed for operation of the trigger. They can be removed in order to preserve battery life. If you remove an LED and then want to reconnect it, note that the rim around the case of the LED has a flat side. The leg on that side is negative.

Adjusting the delay time

The 1M potentiometer (blue knob) provides coarse delay control. Rotate it clockwise to increase the delay time up to about half a second. The 100k potentiometer (brown knob) provides fine delay control. Set the coarse delay first and then tune it with the fine delay.

Adjusting the sensitivity of the photogate

If the photogate is working, you normally don't need to adjust the sensitivity. If, however, you want to adjust the sensitivity, here's the procedure:

First make sure the photogate is working. Then turn the white knob counterclockwise until the photogate indicator LED goes off. Then back off the knob a little bit until the LED comes back on. Adjustments may need to be made if you change the separation of the emitter and detector. If you increase the separation, do so in small steps, testing the photogate and readjusting the sensitivity as needed to ensure that the photogate continues to be aligned and working.

Replacing the timing capacitor to change the delay range

The timing capacitor connected into the circuit is a 0.47- μ f capacitor. This provides up to a half second delay. This is ideal for photographing drops and splashes but may be too long for other situations. You can change the delay range by replacing the 0.47- μ f capacitor with one of smaller value. An extra 0.1- μ f and 0.01- μ f capacitor have been provided for this purpose, and will yield the following time delays.

Capacitor	Time Delay	Location
0.47- μ f (cylindrical)	Half second	(+) to 28H, (-) to 29G
0.1- μ f (labeled "104")	Up to ~1/10 second	28H-29G (nonpolar)
0.01- μ f (labeled "103")	Up to ~1/100 second	28H-29G (nonpolar)

Replacing the 1-kohm resistor with a 100-kohm resistor to increase the reset delay

The 1-kohm resistor from 26C to 29C can be replaced with the extra 100-kohm resistor in order to increase the dead time after a triggering event. During this dead time, the circuit won't trigger. This is useful to prevent secondary events such as a second drop from actuating the circuit. The dead time is approximately equal to the value of the resistor in kilohms divided by 100. For example, the dead time for a 100-kohm resistor would be 1 second.

Replacing components

Due to the nature of an open circuit on a breadboard, components may become dislodged and need to be resealed. Complete instructions for component placement can be found at the link below.

<http://hiviz.com/kits/instructions/spg-du-manual2.htm>