

Instructions for Using the Assembled Schmitt Photogate Trigger with Individual Emitter and Detector (SPG1-A)

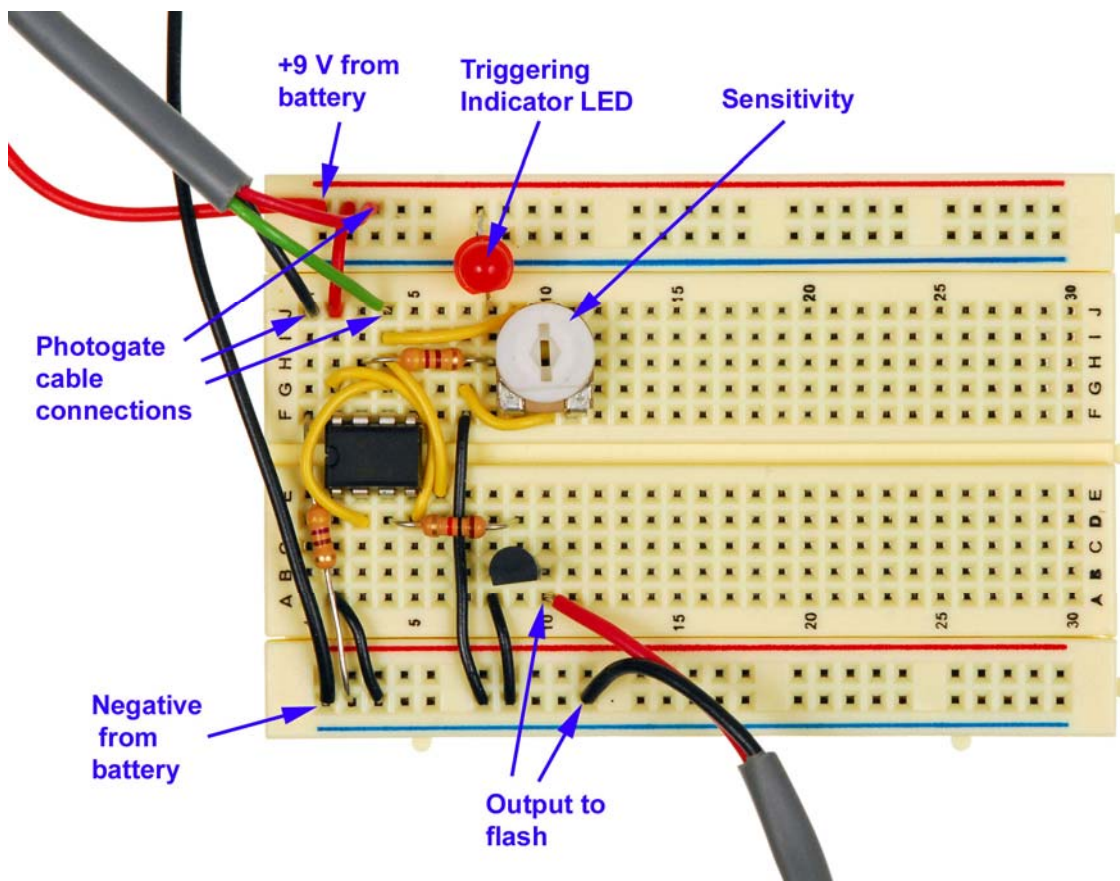

Supplied components

Circuit board with photogate
 Photogate cable with wired emitter and detector
 3-foot, 2-conductor output cable

Battery cable connection

The entire column of holes on the bottom along the blue line is negative (ground). Likewise, the entire column along the red line on the top is +9 V. These two columns are where the red and black cables from the battery clip are connected.

Connecting the photogate cable

The photogate cable has 3 wires: red, black, and green. The photogate cable with emitter and detector has already been prepared. Connect the cable to your circuit as shown to the right.

| Wire | Location |
|-------|----------|
| Red | + |
| Black | 1J |
| Green | 4J |

Connecting the output cable

The output cable has 2 wires: red and black. Connect the black wire to the negative, ground column and the red wire to 10A.

Connect the other end of the output cable to the PC cord from your flash unit. See the following link for illustrated instructions on splicing the output cable to a PC cord or Flash-to-PC adapter:

<http://hiviz.com/kits/instructions/instructions.htm#other>.

Powering the unit

The circuit runs on a 9-V battery. Connect the wires from the battery clip to the +9 V and ground columns. Disconnect the battery when the circuit is not in use. You may also choose to use a 9-V AC/DC adapter to power the unit. Any AC/DC

adapter that provides up to an ampere of direct current at 9 V should do. Here's an example:

http://hiviz.com/kits/ACDC_adapter.htm.

Photogate open indicator LED

When the photogate is aligned and unblocked, the red photogate indicator LED will be on. The LED will go off when the photogate is blocked.

The red LED isn't needed for operation of the trigger. It can be removed in order to preserve battery life. If you remove an LED and then want to reconnect it, note that the rim around the case of the LED has a flat side. The leg on that side is negative.

Adjusting the sensitivity of the photogate

If the photogate is working, you normally don't need to adjust the sensitivity. If, however, you want to adjust the sensitivity, here's the procedure:

First make sure the photogate is working. Then turn the white knob one way or the other until the flash unit discharges spontaneously. Then back off the knob a little bit until the photogate works by passing a finger through it. Adjustments may need to be made one way or the other as the battery weakens.

Replacing components

Due to the nature of an open circuit on a breadboard, components may become dislodged and need to be resealed. Complete instructions for component placement can be found at the link below.

<http://hiviz.com/kits/instructions/spg-manual2.htm>